



# **AW400Rx**

## **User Manual**

**Version 1.0**

**Last Revised April 22, 2009**

**All contents in this manual are copyrighted by ArWest Communications.  
All rights reserved. The information contained herein may not be used, accessed, copied,  
stored, displayed, sold, modified, published, or distributed, or otherwise reproduced without  
express written consent from ArWest Communications.**



# TABLE OF CONTENTS

<b>Preface</b> .....	<b>5</b>
Terms and Conditions .....	5
Regulatory Information .....	6
FCC Class A Compliance .....	6
Canadian Emissions Labeling Requirements .....	7
WEEE Directive .....	7
Glossary .....	9
Related Information .....	10
Technical Assistance .....	10
Return Material Authorization .....	10
<b>Chapter 1. Product Features</b> .....	<b>11</b>
1.1. Introduction .....	11
1.1.1. Operating at Ultra High Frequency Band .....	12
1.1.2. Modulation Technique .....	12
1.1.3. Media Access Control (MAC) .....	13
1.1.4. Operating Modes .....	13
1.1.5. Management Tools .....	13
1.1.6. Security .....	14
<b>Chapter 2. General Description</b> .....	<b>15</b>
2.1. Physical Interfaces .....	15
2.1.1. Serial Data Interface .....	15
2.1.2. Power Interface .....	15
2.1.3. Power Consumption .....	15
2.1.4. Antennas .....	15
<b>Chapter 3. Command Line Interface</b> .....	<b>17</b>
3.1. Command Line Interface Convention .....	18
3.1.1. Software Switching to Command Mode .....	18
3.1.2. Switching to Data Mode .....	19
3.2. Networking Commands .....	20
3.2.1. CONNECT .....	20
3.2.2. LINK .....	20
3.3. Serial Interfacing Commands .....	21

3.3.1. DPORT .....	21
3.3.2. MPORT .....	22
3.4. Special Commands .....	22
3.4.1. ALARM .....	22
3.4.2. BOOT .....	23
3.4.3. HELP .....	23
3.4.4. SAVE .....	23
3.4.5. SLEEP .....	23
3.5. Diagnostics and Identification Commands .....	24
3.5.1. INFO .....	24
3.5.2. STATE .....	25
<b>Appendix A. Technical Specifications .....</b>	<b>27</b>
A.1. Technical Specifications .....	27
A.1.1. Radio receiver .....	27
A.1.2. Modem .....	28
A.1.3. Compliance .....	28
A.1.4. General .....	29
A.1.5. Mechanical Properties For End-product .....	30
A.2. External Connectors .....	30
A.2.1. Antenna Connector .....	30
A.2.2. User Ports' Connector .....	31
<b>Appendix B. Safety Warnings .....</b>	<b>33</b>
B.1. General Warnings .....	34
<b>Appendix C. UHF Radio Usage .....</b>	<b>35</b>
<b>Appendix D. Warranty Terms .....</b>	<b>37</b>

# PREFACE

Thank you for purchasing this product. The materials available in this Manual (the “Manual”) have been prepared by ArWest Communications (“ArWest Communications”) for owners of ArWest Communications products. It is designed to assist owners with the use of the AW400Rx and its use is subject to these terms and conditions (the “Terms and Conditions”).

**Note:** Please read these Terms and Conditions carefully.

## Terms and Conditions

**COPYRIGHT** – All information contained in this Manual is the intellectual property of, and copyrighted material of ArWest Communications. All rights are reserved. You may not use, access, copy, store, display, create derivative works of, sell, modify, publish, distribute, or allow any third party access to, any graphics, content, information or data in this Manual without ArWest Communications’ express written consent and may only use such information for the care and operation of your AW400Rx. The information and data in this Manual are a valuable asset of ArWest Communications and are developed by the expenditure of considerable work, time and money, and are the result of original selection, coordination and arrangement by ArWest Communications.

**TRADEMARKS** – AW400Rx, ArWest Communications® are trademarks or registered trademarks of ArWest Communications. Windows® is a registered trademark of Microsoft Corporation. Product and company names mentioned herein may be trademarks of their respective owners.

**DISCLAIMER OF WARRANTY** – EXCEPT FOR ANY WARRANTIES IN THIS MANUAL OR A WARRANTY CARD ACCOMPANYING THE PRODUCT, THIS MANUAL AND THE AW400Rx ARE PROVIDED “AS-IS.” THERE ARE NO OTHER WARRANTIES. ARWEST COMMUNICATIONS DISCLAIMS ANY IMPLIED WARRANTY OF MERCHANTABILITY OR FITNESS FOR ANY PARTICULAR USE OR PURPOSE. ARWEST COMMUNICATIONS AND ITS DISTRIBUTORS SHALL NOT BE LIABLE FOR TECHNICAL OR EDITORIAL ERRORS OR OMISSIONS CONTAINED HEREIN; NOR FOR INCIDENTAL OR CONSEQUENTIAL DAMAGES RESULTING FROM THE FURNISHING, PERFORMANCE OR USE OF THIS MATERIAL OR THE AW400Rx. SUCH DISCLAIMED DAMAGES INCLUDE BUT ARE NOT LIMITED TO LOSS OF TIME, LOSS OR DESTRUCTION OF DATA, LOSS OF PROFIT, SAVINGS OR REVENUE, OR LOSS OF THE PRODUCT'S USE. IN ADDITION, ARWEST COMMUNICATIONS IS NOT RESPONSIBLE OR LIABLE FOR DAMAGES OR COSTS INCURRED IN CONNECTION WITH OBTAINING SUBSTITUTE PRODUCTS OR SOFTWARE, CLAIMS BY OTHERS, INCONVENIENCE, OR ANY OTHER COSTS. IN ANY EVENT, ARWEST COMMUNICATIONS SHALL HAVE NO LIABILITY FOR DAMAGES OR OTHERWISE TO YOU OR ANY OTHER PERSON OR ENTITY IN EXCESS OF THE PURCHASE PRICE FOR THE AW400Rx.

## **Preface**

Regulatory Information  
FCC Class A Compliance

**LICENSE AGREEMENT** – Use of any computer programs or software supplied by ArWest Communications or downloaded from a ArWest Communications website (the “Software”) in connection with the AW400Rx constitutes acceptance of these Terms and Conditions in this Manual and an agreement to abide by these Terms and Conditions. The user is granted a personal, non-exclusive, non-transferable license to use such Software under the terms stated herein and in any case only with a single AW400Rx or single computer. You may not assign or transfer the Software or this license without the express written consent of ArWest Communications. This license is effective until terminated. You may terminate the license at any time by destroying the Software and Manual. ArWest Communications may terminate the license if you fail to comply with any of the Terms or Conditions. You agree to destroy the Software and manual upon termination of your use of the AW400Rx. All ownership, copyright and other intellectual property rights in and to the Software belong to ArWest Communications. If these license terms are not acceptable, return any unused software and manual.

**CONFIDENTIALITY** – This Manual, its contents and the Software (collectively, the “Confidential Information”) are the confidential and proprietary information of ArWest Communications. You agree to treat ArWest Communications' Confidential Information with a degree of care no less stringent than the degree of care you would use in safeguarding your own most valuable trade secrets. Nothing in this paragraph shall restrict you from disclosing Confidential Information to your employees as may be necessary or appropriate to operate or care for the AW400Rx. Such employees must also keep the Confidentiality Information confidential. In the event you become legally compelled to disclose any of the Confidential Information, you shall give ArWest Communications immediate notice so that it may seek a protective order or other appropriate remedy.

**WEBSITE; OTHER STATEMENTS** – No statement contained at the ArWest Communications website (or any other website) or in any other advertisements or ArWest Communications literature or made by an employee or independent contractor of ArWest Communications modifies these Terms and Conditions (including the Software license, warranty and limitation of liability).

**SAFETY** – Improper use of the AW400Rx can lead to injury to persons or property and/or malfunction of the product. The AW400Rx should only be repaired by authorized ArWest Communications warranty service centers. Users should review and heed the safety warnings in Chapter B on page 33.

**MISCELLANEOUS** – The above Terms and Conditions may be amended, modified, superseded, or canceled, at any time by ArWest Communications. The above Terms and Conditions will be governed by, and construed in accordance with, the laws of the State of California, without reference to conflict of laws.

## **Regulatory Information**

The following sections provide information on this product's compliance with government regulations.

### **FCC Class A Compliance**

This equipment has been tested and found to comply with the limits for a Class A digital device, pursuant to part 15 of the FCC Rules. These limits are designed to provide reasonable protection against harmful interference when the equipment is operated in a commercial environment. This equipment generates,

uses, and can radiate radio frequency energy and, if not installed and used in accordance with the instruction manual, may cause harmful interference to radio communications. Operation of this equipment in a residential area is likely to cause harmful interference in which case the user will be required to correct the interference at his own expense.

**Note:** Any changes or modifications to the equipment not expressly approved by the party responsible for compliance could void your authority to operate such equipment.

## Canadian Emissions Labeling Requirements

This Class A digital apparatus meets all requirements of the Canadian Interference-Causing Equipment Regulations.

Cet appareil numérique de la classe A respecte toutes les exigences du Règlement sur le matériel brouilleur du Canada.

## WEEE Directive

The following information is for EU-member states only:

The use of the symbol indicates that this product may not be treated as household waste. By ensuring this product is disposed of correctly, you will help prevent potential negative consequences for the environment and human health, which could otherwise be caused by inappropriate waste handling of this product. For more detailed information about the take-back and recycling of this product, please contact your supplier where you purchased the product or consult.





## DECLARATION of CONFORMITY

According to ISO/IEC Guide 22 and EN45014

Manufacturer's Name: ArWest Communications Corporation  
Manufacturer's Address: 1731 Technology Drive  
San Jose, CA 95110  
USA

declares, that the products

Product Name: AW400Tx OEM transceiver and AW400Rx OEM receiver  
Product Number: 01-00012-200, 01-00011-110  
Product Options: All

conforms to the following Product Specification:

EMC:  
Directive 89/336/EEC EN 300 113 -1, EN 300 113 - 2  
EN 301 489 -1, EN 301 489 - 5

Supplementary Information:

The product herewith complies with the essential requirements of the directive 1999/5/EC of the European Parliament and of the Council of 9 March 1999 on radio equipment and telecommunications terminal equipment (R&TTE) and the mutual recognition of their conformity and carries the CE marking accordingly

- 1) These products were tested in a typical configuration with ArWest Communications Corporation products
- 2) AW400Rx is identical to AW400Tx, but without transmitting part

This Declaration of Conformity is based on the following documents:

Doc No	Type of Product	Test Specification	Laboratory / Date of issue
3157867MPK-001	AW400Tx/AW400Rx	EN 300 113-2	Intertek / Menlo Park 24.12.2008
3157867MPK-001	AW400Tx/AW400Rx	EN 300 113-1	Intertek / Menlo Park 24.12.2008
3157867MPK-002	AW400Tx/AW400Rx	EN 301 489-1	Intertek / Menlo Park 31.08.2008
3157867MPK-002	AW400Tx/AW400Rx	EN 301 489-5	Intertek / Menlo Park 31.08.2008

V. Zhukov

San Jose, March 30, 2009

Vladimir Zhukov, Product Regulations Manager



## Glossary

μC	Micro Controller
AGC	Automatic Gain Control
ALC	Automatic Output Power Level Control
AWGN	Additive White Gaussian Noise
BER	Bit Error Rate
BERT	Bit Error Rate Test
CLI	Command Line Interface
CMOS	Complementary Metal-Oxide Semiconductor
CRC	Cyclic Redundancy Code
CTS	Clear To Send
CW	Continues Wave
DBPSK	Differential Binary Phase Shift Keying
DC	Direct Current
DCD	Data Carrier Detect
DQPSK	Differential Quadrature Phase Shift Keying
DSP	Digital Signal Processing
DSR	Data Set Ready
DTE	Data Terminal Equipment
DTR	Data Terminal Ready
ETSI	European Telecommunications Standardization Institute
FCC	Federal Communications Commission
FEC	Forward Error Correction
FIFO	First-Input-First-Output
FSK	Frequency Shift Keying
GMSK	Minimum Shift Keying with Gaussian filtering
GUI	Graphical User Interface
HPA	High Power Amplifier
I/O	Input/Output
IF	Intermediate Frequency
LED	Light Emitting Diode
LLC	Logic Link Control
LNA	Low Noise Amplifier
MAC	Media Access Control
MSK	Minimum-shift keying
MTBF	Mean Time Between Failures
MTTR	Mean Time To Repair
PA	Power Amplifier
PCB	Printed Circuit Board
PDA	Personal Digital Assistant
PLL	Phase-Lock Loop
PMP	Point-to-Multipoint
PSK	Phase Shift Keying
PTP	Point-to-Point

## **Preface**

Related Information  
Technical Assistance

QAM	Quadrature Amplitude Modulation
QPSK	Quadrature Phase Shift Keying
RF	Radio Frequency
RSSI	Received Signal Strength Indication
RTK	Real-time Kinematics
RTS	Request To Send
RX	Receive(r)
SCADA	Supervisor Control and Data Acquisition
SRAM	Static Random Access Memory
TDD	Time Division Duplex
TDM	Time Division Multiplexing
TDMA	Time Division Multiple Access
TPC	Turbo Product Codes
TPO	Transmitter Output Power
TTL	Transistor-Transistor-Logic
TX	Transmit(ter)
UART	Universal Asynchronous Receiver/Transmitter
VHF	Ultra High Frequency (300-3000 MHz)
UIM	User Identify Module
VSWR	Voltage Standing Wave Ratio
FIRMWARE	A software program or a set of instructions embedded on a hardware device
SOFTWARE	Computer program for communication with a hardware device

## **Related Information**

### **Technical Assistance**

If you have a problem and cannot find the information you need in the product documentation, contact your local dealer. Alternatively, request technical support using the ArWest Communications World Wide Web site at: [www.arwestcom.com](http://www.arwestcom.com)

### **Return Material Authorization**

Initially, the customer contacts support to report a problem. Please refer to support: [support@arwestcom.com](mailto:support@arwestcom.com)

If support determines the problem cannot be resolved over e-mail/internet, it will authorize the return of the unit for repair or replacement, depending on the nature of the problem.

# PRODUCT FEATURES

## 1.1. Introduction

AW400Rx DSP based integrated UHF receiver is the single board OEM wireless receiver intended for SCADA, outdoor telemetry applications and receiving of differential corrections and additional information by terrestrial radio channels between two GNSS receivers.



**Figure 1-1. AW400Rx**

The UHF receiver is capable of receiving RF signals through a 50 Ohm impedance external antenna port.

AW400Rx delivers a reliable radio link at up to 38.4 kbps over the air for the 25 kHz channel spacing, 30 kbps for 20 kHz, 19.2 kbps for 12.5 kHz, and 9.6 kbps for 6.25 kHz. The module requires a regulated DC voltage power supply  $3.6\text{ V} \pm 5\%$ .

The delivered product is a wireless system, which includes:

- AW400Rx – UHF Radio receiver;
- AWLaunch – Windows based Unit Configuration and Maintenance Software Application running on a IBM PC compatible computer and connecting to the device over RS-232 interface or USB-to-Serial adapter.

The setting can be done through the built-in Command Line interface (CLI), or through the configuration and maintenance application software running either on PC – AWLaunch.

The diagnostic feature of the AW400Rx system provides the information to monitor and maintain user's communications link. The output transmit power, receive signal strength (RSSI), antenna/feedline condition, and data decode performance are transmitted online without application interruption.

The product is designed for maximum performance and reliability even in the harshest environments. Plug and play at its best, robust, withstanding the most adverse of conditions.

## Product Features

Introduction

Operating at Ultra High Frequency Band

### 1.1.1. Operating at Ultra High Frequency Band

AW400Rx operates in UHF frequency band covering both licensed and unlicensed frequencies. The following are its key benefits:

1. Operating in UHF frequency band will provide a non-line of sight connection.
2. Single radio system covers the whole UHF frequency band from 406 to 470 MHz;
3. User selectable channel spacing (25 kHz, 20 kHz, 12.5 kHz or 6.25 kHz);

### 1.1.2. Modulation Technique

The design is based on high-level modulation techniques which include:

Modulation/ Channel Spacing	6.25 kHz	12.5 kHz	20 kHz	25 kHz
DBPSK – Differential Binary Phase Shift Keying	2.4 kbps	4.8 kbps	7.5 kbps	9.6 kbps
DQPSK – Differential Quadrature Phase Shift Keying	4.8 kbps	9.6 kbps	15 kbps	19.2 kbps
D8PSK – Eight Phase Shift Keying	7.2 kbps	14.4 kbps	22.5kbps	28.8 kbps
D16QAM – Sixteen Quadrature Amplitude Modulation	9.6 kbps	19.2 kbps	30 kbps	38.4 kbps
GMSK – Minimal Shift Keying with Gaussian Filtering	2.4 kbps	4.8 kbps	7.5 kbps	9.6 kbps
4FSK- Four Level Frequency Shift Keying	N/A <sup>1</sup>	9.6 kbps	15.0 kbps	19.2 kbps

1. N/A – Not Applicable

### **1.1.3. Media Access Control (MAC)**

The following Media Access protocols are available for AW400Rx modem:

1. Simplex protocols (Simplex Base, Simplex Remote, and Repeater) are developed primarily for GNSS applications.
2. Sleep mode is an investment provided by MAC sub-layer that provides additional power saving. The wakeup from Sleep mode is user selectable either by an internal real-time clock, or by an external controller through the data interface control lines (RTS or DTR), or by SLEEP input line (CMOS/TTL compatible input lines).

### **1.1.4. Operating Modes**

The operating modes for AW400Rx can be set through the CLI, and/or through AWLaunch. The following operating mode are available for AW400Rx:

- The sleep mode has automatic transmitter activation by an internal real-time clock, or by an external controller through the data interface control lines (RTS and DTR), or by the triggering of the external Sense Inputs.

### **1.1.5. Management Tools**

The built-in management tools along with AWLaunch (configuration and monitoring software application) will provide the following benefits:

1. Easy user's interface for system configuration and monitoring using well developed CLI or intuitive GUI.
2. An ability to monitor status, alarms and radio performance through the intuitive GUI.
3. Software upgrades and improvements can be downloaded from AWLaunch to the units connected with PC/PDA.

## **Product Features**

Introduction

Security

### **1.1.6. Security**

The system provides wireless media access protection as well as data encryption. The following are its key features and benefits:

1. The Key Sequence generated by Pseudo-random generator scrambles the fully formatted frame (including Frame's CRC). This provides the wireless media access protection.
2. User selectable Frequency Hopping Pattern provides another level of the wireless media access protection.

At the same time it allows operators to increase the number of links deployed in the same location.

# **GENERAL DESCRIPTION**

## **2.1. Physical Interfaces**

### **2.1.1. Serial Data Interface**

The serial asynchronous interface allows connection to external serial devices. It is shared between user data and unit's command/status information. All commonly supported baud rates, parity and bit configurations are available up to 115.2 kbps.

### **2.1.2. Power Interface**

The power interface allows connection to an unregulated DC power source. The DC power source (third-party or user supplied) must provide DC power of  $3.6V \pm 5\%$  DC.

The standalone unit's RF interface is a 50-ohm impedance matched standard MMCX connector as required by regulation.

### **2.1.3. Power Consumption**

Power consumption of the UHF radio receiver is less than 1000mW (refer to Table 2-1 for details).

**Table 2-1. Power Consumption**

<b>Operating Mode / Description</b>	<b>Consumption</b>
Sleep Mode	300 mW
Standby Mode, ordered by SLEEP input pin	500 $\mu$ W

### **2.1.4. Antennas**

Antenna type depends on the site requirements, and may be directional or omni-directional.

## **General Description**

Physical Interfaces

Antennas



# COMMAND LINE INTERFACE

The built-in user-friendly Command Line Interface (CLI) allows user to perform a full configuration of the unit and read the statistics and alarm status. It is the most powerful tool to configure the unit. It makes changes to all possible settings that system will not be able to determine automatically.

The CLI commands allow user to configure and reconfigure the unit's settings. The user configuration parameters that could be changed through the CLI are:

- Data Port Settings
  - Baud Rate
  - Data Bits (8, 7)
  - Parity (Odd, Even, None)
  - Flow control (None or RTS/CTS)
- Alarm Settings
- Radio Operation Modes
- Sleep modes
  - On/Off
  - Activate by internal real-time clock
  - Activate through RTS/CTS lines
  - Activate by external sense lines
  - Activate by any combination of the parameters mentioned before

**Note:** The unit's configuration that is set or modified through the CLI will be lost after unit's reboot, unless the saving operation is used to store a new setting in the unit's configuration file.

The CLI commands also provide filing operations, which include:

- Downloading
  - Unit's Configuration files
  - Software Images
- Uploading Unit's Configuration files
- Saving into the configuration files the configuration parameters modified through the CLI.

## Command Line Interface

Command Line Interface Convention  
Software Switching to Command Mode

### 3.1. Command Line Interface Convention

The following convention is implemented in AW400Rx Command Line Interface (CLI):

- The Carriage Return/Line Feed (CR/LF, 0x0D/0x0A) is a command delimiter.
- The Carriage Return/Line Feed (CR/LF, 0x0D/0x0A) is a reply delimiter followed by the “CLI>” prompt if Echo option is On.
- The Carriage Return/Line Feed (CR/LF, 0x0D/0x0A) is a reply delimiter if Echo option is Off (default option).
- The 2-digit number followed by “@” in the unit’s reply indicates the error code (refer to Table 3-1 for description), if Echo Off is selected, otherwise the error message is displayed.
- A successfully performed command is replied by @00 code, if Echo Off is selected, otherwise the set value is replied.
- A command with the certain [*Parameter Name*] and blank [*Parameter List*] displays the current settings for a given parameter.
- To set the mode ordered by CLI commands as permanent User Setting (the setting automatically selected for the boot-up unit) the SAVE command must be asserted.
- [/?] orders to show the help information for the given command.
- Commands are not key sensitive; small, none capital characters can be used to enter CLI commands.

**Table 3-1. Command Line Interface Error Codes**

Error Code	Short Description
0x01	Command Syntax Error. A command followed by “/?” displays a command usage.
0x02	The parameter has a format error. A command with the certain [ <i>Parameter Name</i> ] followed by “/?” displays the format and range of the variable.
0x03	The parameter is out of allowed range. A command with the certain [ <i>Parameter Name</i> ] followed by “/?” displays the format and range of the variable.
0x04	The command is not valid for specific radio model. To display the list of available commands, the HELP command must be used (see “Software Switching to Command Mode” ).
0x05	Unspecified Error

#### 3.1.1. Software Switching to Command Mode

Software Switching to Maintenance Mode can be utilized if Data/Maintenance Port (DP/MP) control line is set to High Z (or 3.3v) level. To switch to Maintenance mode the special byte-sequences with special meanings are used:

- Escape-Sequence: “+++” with 20 ms guard time before and after the command characters
- Escape-Acknowledge: “@00<CR><LF>” 20 ms toggling on CTS control line needed to acknowledge switching from Data to Maintenance mode and vice versa. In Maintenance mode, the unit’s serial port must keep CTS line always active.

## Happy Flow

1. In data-mode the unit starts looking for the Escape-sequence if there is no data from DTE for more than 20 ms (Start Guard Time).
2. If the unit detects the Escape-Sequence:
  - The transmitter continues sending over the air the data received from DTE before Escape-Sequence and buffers the data from DTE;
  - The Receiver immediately stops forwarding to DTE the data received over the air and buffers it instead.
3. The radio unit waits for 20 ms and then sends Escape-Acknowledge to DTE if there is no data from DTE during 20 ms of Stop Guard Time.
4. The unit goes to Maintenance mode and discards Escape-Sequence from input buffer. The modem is immediately ready to receive commands. At the same time it continues buffering the data received over the air since step 2.

## Escape-Sequence in Data

During its waiting in step 3, the unit receives data from DTE:

- The unit sends buffered Escape-Sequence from DTE to the air;
- The unit sends all buffered data received from the air since step 2 to DTE and stays in data-mode (i.e. transmits data received from DTE over the air – including the just received, unexpected, data and forwards data received over the air to DTE.)

### 3.1.2. Switching to Data Mode

- DTE sends the CLI command „DATAMODE<CR><LF>“ to the unit.
- Unit answers with Escape-Acknowledge („@00<CR><LF>“) and immediately goes to datamode, so that the DTE can start sending data as soon as the Escape-Acknowledge has been received.
- If no valid CLI commands received from DTE within 1 minute, the unit will automatically switch back to data-mode.

**Note:** The data received over the air could be lost due to Rx buffer overflow if the unit stays in Maintenance mode longer than 15 second.

## Command Line Interface

Networking Commands

CONNECT

## 3.2. Networking Commands

### 3.2.1. CONNECT

To connect the radio unit through the local maintenance serial port or to establish the link with the remote unit in the Point-to-Multipoint network, the CONNECT command must be used.

CONNECT [Unit\_Numb] [/?]

Where the Unit\_Numb is an assigned decimal number for the unit to be connected. To get the complete unit list, the CONNECT command must be used with no parameter. The list of units in the Point-to-Point link with the connection established with remote unit is shown in Figure 3-1:

Unit	Serial Number	Connect
BS	003578659922	
1	003574459923	C

Figure 3-1. Connection List

To disconnect from the remote unit and connect to the local unit, the parameter (Unit\_Numb) must be equal to 0x00.

### 3.2.2. LINK

The LINK command is responsible for configuring radio's operation mode. It has six parameters listed below.

LINK [*Parameter Name*] [*Parameters List*] [/?]

Parameter Name	Parameter List
CHAN	Selects the Channel Number: CN = 1 to 32. Each Channel is defined by three parameters: Carrier Frequency, Channel Spacing and Allowed Output Power level. CN = 0 is reserved to set up the Frequency Automatic scanning mode. The LINK CHAN 0 command also forces the radio modem to continue scanning starting from the channel currently selected by automatic scanning algorithm. In Automatic scanning mode, to check the channel currently used or scanned, the STATE command must be used
FEC	0 – Disable Forward Error Correction, a default setting (see note below) 1 – Enable Forward Error Correction (see note below)
FHOP	(1 – 32) – Frequency Hoping Pattern number LINK FHOP command can be processed only if the Channel Map (up to 32 channels) is defined by AWLaunch or by MAP command.
PROT	1 – “Simplex Receiver” a default setting (see note below) 7 – “TRMB Receiver” (used with GMSK modulation) 12 – “Transparent w/EOT” Receiver (used with GMSK and 4FSK) 14 – “STL Receiver” (used with 4FSK modulation)
SCRAM	0 – No Scrambling (a default setting) (1 – 255) – Seed for Pseudo-Random Sequence Generator

**Note:** LINK FHOP and LINK CHAN commands can be processed only if Frequency Map is defined.

Auto-scanning may not start automatically, only when scanning requested via CLI command (see LINK CHAN 0 and STATE commands).

The frequency defined by CHAN parameter is not valid if Frequency Hopping mode is selected.

The radio link with GMSK and 4FSK modulations are used by Non-ArWest protocols only.

Enabling FEC via LINK FEC command provides different options for different protocols:

- Enables Read-Solomon encoding for frame's header used by ArWest proprietary protocols
- Enables Hamming encoding for Trimble and Pacific Crest compatible protocols
- Enables Trellis encoding for Satel compatible protocol

For ArWest proprietary protocols, the Read-Solomon FEC encoding is always applied to data payload.

LINK ADDR and LINK CLKCORR commands are not recommended for using on site of End Users.

## 3.3. Serial Interfacing Commands

### 3.3.1. DPORT

The DPORT is an object that responsible for data port interface configurations like Bit Rate, Flow Control, etc.

DPORT [*Parameter Name*] [*Parameters List*] [/?]

Parameter Name	Parameter List
RATE	0 – Maintenance Port baud rate, a default setting 1 – 1200 baud 2 – 2400 baud 3 – 4800 baud 4 – 9600 baud 5 – 14400 baud 6 – 19200 baud 7 – 38400 baud 8 – 57600 baud 9 – 115200 baud, a default setting
BITS	Set number of bits in one byte (8 or 7) 8 is a default setting
PARITY	0 – None, a default setting 1 – Odd 2 – Even
FLOW	0 – None, a default setting 1 – Not used 2 – HW (RTS/CTS)

## Command Line Interface

Special Commands

MPORT

### 3.3.2. MPORT

The MPORT is an object that responsible for maintenance serial port interface configurations such as data rate and number of bits in a byte.

MPORT [*Parameter Name*] [*Parameters List*] [/?]

Parameter Name	Parameter List
RATE	0 – Auto. 1 – 1200 baud 2 – 2400 baud 3 – 4800 baud 4 – 9600 baud 5 – 14400 baud 6 – 19200 baud 7 – 38400 baud 8 – 57600 baud 9 – 115200 baud, a default setting

**Note:** ArWest radio modem's does not support data flow and parity on the maintenance serial port.

MPORT operates using 8 bits in one byte fixed (not configurable).

The radio modem with none-dedicated maintenance serial port must keep CTS line always active in MPORT mode (DP/MP is low).

## 3.4. Special Commands

### 3.4.1. ALARM

The ALARM command is intended to set up the alarm indication mode and alarm control lines' behavior.

ALARM [*Parameter Name*] [*Parameters List*] [/?]

Parameter Name	Parameter List
TTL1	0 – TTL_OUT1 = logic "1" 1 – TTL_OUT1 = TTL_IN, received from remote unit (default settings)
TTL2	0 – TTL_OUT2 = logic "1" 1 – TTL_OUT2 = TTL_IN2, received from remote unit (default settings) 2 – TTL_OUT2 = SYNC Loss 3 – TTL_OUT2 = BER > BERTH or SYNC Loss
BERTH	1– BER Threshold $>10^{-3}$ (default threshold level for BER) 2 – BER Threshold BER $>10^{-2}$

The Alarm LED must indicate the SYNC Loss and BER exceeding the defined threshold.

**Note:** The BERTH 1 / 2 is optional for TTL2 = 3 condition, otherwise the BERT alarm is off

## 3.4.2. BOOT

The BOOT command is intended to reboot the unit using selected user settings. Two options are available, to use the default user settings defined by dealer or to use the settings defined by end-user

BOOT [*Parameter Name*] [*Parameters List*] [/?]

Parameter Name	Parameter List
CFG	0 – selects the default user settings 1 – selects user modified settings

The BOOT command with no parameters selects the user settings defined by the prior “parameterized” BOOT commands.

## 3.4.3. HELP

The HELP command types the list of all available commands:

```

HELP      - Display this usage
BOOT      - Reboot the unit
LINK      - RF Link Operation Mode
DPORT     - Data Port Configuration
MPORT     - Maintenance Port Configuration
ALARM     - Alarm Indication and Alarm Control Configuration
SLEEP     - Sleep Mode Configuration
CONNECT   - Connect to Specified Unit
STATE     - Display Status and Statistics
SAVE      - Save Current Configuration into Configuration File
INFO      - Display Product ID along with Hardware/Software Versions
DATAMODE  - Exit Maintenance Mode
[COMMAND] /? - Display Command Usage
    
```

## 3.4.4. SAVE

The SAVE command is intended to store the unit’s currently used configuration into the User Configuration file. The configuration stored in the User Configuration file is activated by automatically after unit’s reboot.

## 3.4.5. SLEEP

The SLEEP command determines the sleep mode parameters. The sleeping AW400Rx can be activated by real-time CLK, DTR/RTS lines, and command received through TTL inputs. The user can select one, two, or all three conditions.

## Command Line Interface

Diagnostics and Identification Commands

INFO

SLEEP [*Parameter Name*] [*Parameters List*] [/?]

Parameter Name	Parameter List
CLK	0 – Do not activate by internal real-time clock (1 – 255) – Activate by internal real-time clock after 100 to 25500 msec of sleeping
HW	0 – Do not activate through DTR/RTS lines 1 – Activate through DTR/RTS lines
TTL	0 – Do not activate by external sense lines 1 – Activate by external sense lines
GTS	0 – Disable Sleep mode (default) (1 – 255) – Go to sleep mode if there is no activity in 10 to 2550 msec

## 3.5. Diagnostics and Identification Commands

### 3.5.1. INFO

The INFO command is used to retrieve the Radio ID along with its Hardware version, the loaded real-time software version/revision and BootLoader's version/revision.

INFO [*Parameter Name*] [*Parameters List*] [/?]

Parameter Name	Parameter List
ID	Product ID
SN	Six bytes Serial Number (SN)
HW	1.0 – hardware version in numeric “Major.Minor” format
SW	Ver. 1.0 Rev. A – displays software's version in numeric “Major.Minor” format and revision in numeric format (range from 01 to 99) for engineering releases and alphabetic format (A to Z) for manufacturing releases
BL	Ver. 1.0 Rev. A – displays BootLoader's version in numeric “Major.Minor” format and revision in numeric format (range from 01 to 99) for engineering releases and alphabetic format (A to Z) for manufacturing releases

The INFO command without Parameter Name indicates all values:

```
AW400Rx UHF Radio Modem.  
Product ID = 33  
S/N = 000000 020303  
Hardware = Ver. 1.0  
Software = Ver. 1.8 Rev. 14  
BootLoader = Ver. 2.0 Rev. 02
```



## 3.5.2. STATE

The STATE command is used to check the state of the wireless link, the unit in the link, and the alarm control lines. To specify a radio unit (local or remote), the CONNECT command must be used in prior of STATE command using.

STATE [*Parameter Name*] [*Parameters List*] [/?]

Parameter Name	Parameter List
RSSI	-52 to -116 dBm – Indicates the Receive Signal Strength in dBm
BER	1.0E-6 to 9.9E-3 – Indicates the BER level
FREQ	406.000000 to 470.000000 MHz – Displays the central frequency of the operating channel
CHAN	1 to 9601 – Displays the selected or currently scanned frequency channel
TEMP	-30°C to 100°C – Displays the temperature inside of enclosure
SYNC	1 – Indicates the established link, 0 – if link is not established yet

The STATE command without Parameter Name indicates all values:

```
RSSI = -110 dBm
BER = < 2.3E-5
FREQ = 140.000000 MHz
CHAN = 10
TEMP = 70C
SYNC = 1
MODE = FIXED
```

**Note:** The indicated receive signal strength (RSSI) is equal to -147 dBm if there is no signal received from transmitter.

## **Command Line Interface**

Diagnostics and Identification Commands

STATE

# TECHNICAL SPECIFICATIONS

AW400Rx DSP based integrated UHF receiver is the single board OEM wireless receiver intended for SCADA, outdoor telemetry applications and transmission /receiving of differential corrections and additional information by terrestrial radio channels between two GNSS receivers.

It supports the following modulation methods: GMSK, DBPSK, DQPSK, D8PSK, D16QAM.

## A.1. Technical Specifications

### A.1.1. Radio receiver

**Table A-1. Radio receiver Specifications**

Component	Details
Frequency Range	406-470 MHz
Channel Spacing	25/20/12.5/6.25 kHz
Carrier Frequency Stability	±1 ppm
Modulation	GMSK/4FSK/DBPSK/DQPSK/ D8PSK/D16QAM
Communication Mode	Simplex

**Table A-2. Radio Receiver Specifications**

Component	Details
Receiver Sensitivity for DBPSK (BER $1 \times 10^{-4}$ )	-113 dBm for 25 kHz Channel Spacing, -113 dBm for 20 kHz Channel Spacing, -114 dBm for 12.5 kHz Channel Spacing, -114 dBm for 6.25 kHz Channel Spacing
Receiver Sensitivity for DQPSK (BER $1 \times 10^{-4}$ )	-110 dBm for 25 kHz Channel Spacing -110 dBm for 20 kHz Channel Spacing -111 dBm for 12.5 kHz Channel Spacing -111 dBm for 6.25 kHz Channel Spacing
Receiver Dynamic Range	-119 to -10dBm

## A.1.2. Modem

Figure A-1. Modem Specifications

Component	Details
Interface	DSP UART (serial port)
Interface Connector	16-lead Connector
Data Speed of Serial Interface	9600 - 115200 bps
Data Rate of Radio Interface (25 kHz Channel Spacing)	9600 bps – DBPSK/GMSK 19200 bps – DQPSK 28800 bps – D8PSK 38400 bps – D16QAM
Data Rate Radio Interface (20 kHz Channel Spacing)	7500 bps – DBPSK/GMSK 15000 bps – DQPSK 22500 bps – D8PSK 30000 bps – D16QAM
Data Rate Radio Interface (12.5 kHz Channel Spacing)	4800 bps – DBPSK/GMSK 9600 bps – DQPSK 14400 bps – D8PSK 19200 bps – D16QAM
Data Rate Radio Interface (6.25 kHz Channel Spacing)	2400 bps – DBPSK 4800 bps – DQPSK 7200 bps – D8PSK 9600 bps – D16QAM
Forward Error Correction (FEC)	Reed-Solomon Error Correction
Data scrambling	Yes

## A.1.3. Compliance

Component	Details
FCC	FCC Part 90
Industry Canada	RSS-210
ETSI	ETSI EN 300 113-2, ETSI EN 301 489-1, ETSI EN 301 489-5

## A.1.4. General

Component	Details
Input Voltage	3.6 V $\pm$ 5%
Power Consumption (max)	1 W
Operation Temperature	-40°C - +60°C
Storage Temperature	-40°C - +80°C
Dimensions	L: 80 mm x W: 46.5 mm x H: 7.6 / 9.5 mm
Weight	40 g

## Features

- DSP-Modem
- Multi-Modulation Technologies
- Zero-IF Technologies
- 406-470 MHz Frequency Range
- Up to 115200 bps Data Rate
- Embedded Firmware Compensation for Operation at Extremely Low and High Temperatures
- Compact Design

## Technical Specifications

External Connectors

Mechanical Properties For End-product

### A.1.5. Mechanical Properties For End-product

Dimensions for PCB Mounted Enclosure:

80 mm x W: 46.5 mm x H: 7.6/9.5 mm (3.15" x 1.83" x 0.3")

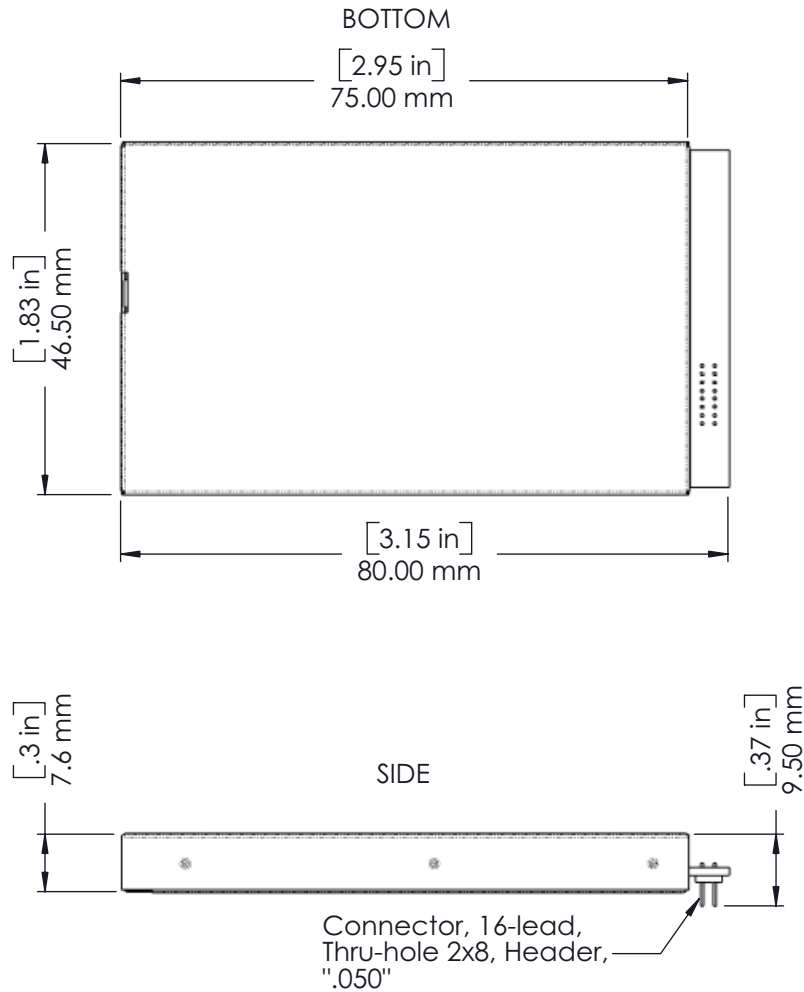

## A.2. External Connectors

### A.2.1. Antenna Connector

J2 is Antenna Input / Output Connector: MMCX RIGHT ANGLE PCB JACK, AMPHENOL P/N 908-24100.

## A.2.2. User Ports' Connector

The user ports' connector is used to provide connection with an external DTE or with the PC running AWLaunch management software applications.

**Note:** The RS232-to-TTL adapter must be used to provide physical level compatibility between COM port of PC running AWLaunch and AW400Rx user interface port.

AW400Rx in PCB mounted enclosure uses 16-Lead Header Connector, ECS Corp. P/N 9616-D1-01-03.

PIN #	Signal Designator	Signal name	Description	I/O	Comments
1	GND	GND	Ground	-	Signal and Chassis Ground
2	DSP UART 1	TXD	Transmit Data	TTL Input	Serial Data Input
3	DSP UART 2	RXD	Receive Data	TTL Output	Output for received serial data
4	DPORT-5	DTR or DP/MP	Data Terminal Ready	TTL Input	Control line can be used as a backup method for entering Command mode: (0V) - Data Mode, (3.3V) - Command Mode An internal 10K pull-down enables Data Mode if this signal is left unconnected.
5	DPORT1	CTS	Clear to Send	TTL Output	Used to control transmit flow from the user to the radio: (0V) – Transmit buffer not full, continue transmitting (3.3V) – Transmit buffer full, stop transmitting
6	TTLI1	SLEEP	Sleeps/wakes radio Receive only	TTL Input	In sleep mode, all radio functions are disabled consuming less than 50µA. An internal 10K pull-down wakes up the radio if this signal is left unconnected. At wake up, any user programmed configuration settings are refreshed from flash memory, clearing any temporary settings that may have been set: (3.3V) – Sleep Radio; (0V) – Wake Radio As an option could be used as TTL Input Line 1.
7	DPORT3	DCD	Data Carrier Detect	TTL Output	Used by remotes to indicate that the remote has successfully acquired the signal from base station: (0V) 1 – Carrier detected (synchronized) (3.3V) 0 – No carrier detected (not synchronized)
8	DPORT4	RTS	Request to Send	TTL Input	Gates the flow of receive data from the radio to the user on or off. An internal 10K pull-down enables data receive if this signal is left unconnected. In normal operation, this signal should be asserted: (0V) – Receive data (RxD) enabled (3.3V) – Receive data (RxD) disabled
9	DPORT2	DSR	Data Set Ready	TTL Output	Used to control transmit flow from the user to the radio: (0V) 1 – Receive buffer has data to transfer; (3.3V) 0 – Receive buffer is empty
10	RES CONT	RESCONT	Reset Control	TTL Input	Reset the radio by shortening this pin to the ground.
11	TTLO1	TTLOUT1	TTL Output Line 1	TTL Output	Reserve line

## Technical Specifications

External Connectors  
User Ports' Connector

<b>PIN #</b>	<b>Signal Designator</b>	<b>Signal name</b>	<b>Description</b>	<b>I/O</b>	<b>Comments</b>
12	TTLO2	TTLOUT2	TTL Output Line 2	TTL Output	Reserve line
13	-	-	-	-	-
14	-	-	-	-	-
15	-	-	-	-	-
16	VCC36	PWR	Power Supply	External	Regulated positive 3.6 V DC from ext. Power Supply.



# **SAFETY WARNINGS**

Read these instructions.

- Keep these instructions.
- Heed all warnings.
- Follow all instructions.
- Clean only with a damp cloth.
- Do not block any of the ventilation openings. Install in accordance with the manufacturer's instructions.
- Do not install near any heat sources such as radiators, heat registers, stoves, or other apparatus (including amplifiers) that produce heat.
- Protect the power cord from being walked on or pinched particularly at plugs, convenience receptacles, and the point where they exit from the apparatus.
- Only use attachments/accessories specified by the manufacturer.
- Refer all servicing to qualified service personnel. Servicing is required when the apparatus has been damaged in any way, such as power-supply cord or plug is damaged, liquid has been spilled or objects have fallen into the apparatus, or has been dropped.
- Apparatus shall not be exposed to dripping or splashing and no objects filled with liquids, shall be placed on the apparatus.

## Safety Warnings

### General Warnings

## B.1. General Warnings

This product should never be used:

- Without the user thoroughly understanding operator's manual.
- After disabling safety systems or altering the product.
- With unauthorized accessories.
- Contrary to applicable laws, rules, and regulations.

**DANGER: THE AW400RX SHOULD NEVER BE USED IN DANGEROUS ENVIRONMENTS.**

# **UHF RADIO USAGE**

Many countries require a license for radio users (such as the United States). Be sure you comply with all local laws while operating a UHF radio.

The quality and strength of the UHF signals translates into range for UHF communications.

The system's range will greatly depend on the local conditions. Topography, local communications and even meteorological conditions play a major role in the possible range of communications.

If needed, use a scanner to find clear channels for communication.

## UHF Radio Usage

# **WARRANTY TERMS**

ArWest Communications Corp., Inc. (“Company”) warrants, to the end-user only, that the Narrow Band Radio Modems (“Radios”) purchased (a) conforms to the Company’s published specifications for the model purchased, and (b) is free from defects in material or workmanship. The duration of this warranty is twelve (12) months from date of purchase and any claim for breach of warranty must be brought to the Company’s attention within such twelve (12) month<sup>1</sup> period and the Receiver must be returned for action on any such claim within twelve (12) months from the date of purchase. Within a reasonable period of time after a claim, the Company will correct any failure of the Radio to conform to specifications or any defect in materials or workmanship, or replace the Radio, or, at its option, provide a full refund of the purchase price. A repaired or replaced product is warranted for 90 days from the date of return shipment to the buyer, or for the balance of the original warranty period, whichever is longer. These remedies are the buyer’s exclusive remedies for breach of warranty.

To obtain warranty service, the buyer must return the Radio, postage-paid, with proof of the date of original purchase and the buyer's return address to the Company or an authorized service center. The Company will not be responsible for any loss or damage to the product incurred while it is in transit or is being shipped for repair. It is the buyer's responsibility to arrange for insurance, if the buyer so desires.

The Company does not warrant (a) any product, components or parts not manufactured by the Company, (b) defects caused by failure to provide a suitable installation environment for the Radio, (c) damage caused by disasters such as fire, flood, wind, and lightning, (e) damage caused by unauthorized attachments or modification, (f) damage during shipment, (g) any other abuse or misuse by the buyer, (h) that the Radio will be free from any claim for infringement of any patent, trademark, copyright or other proprietary right, including trade secrets.

THE FOREGOING WARRANTIES ARE IN LIEU OF ALL OTHER WARRANTIES, EXPRESS OR IMPLIED, INCLUDING BUT NOT LIMITED TO THE IMPLIED WARRANTIES OF MERCHANTABILITY AND FITNESS FOR A PARTICULAR PURPOSE, AND IF APPLICABLE, IMPLIED WARRANTIES UNDER ARTICLE 35 OF THE UNITED NATIONS CONVENTION ON CONTRACTS FOR THE INTERNATIONAL SALE OF GOODS.

IN NO CASE SHALL THE COMPANY BE LIABLE FOR ANY SPECIAL, INCIDENTAL, OR CONSEQUENTIAL DAMAGES ARISING DIRECTLY OR INDIRECTLY OUT OF THE OWNERSHIP, USE OR OPERATION OF THE RADIO REGARDLESS OF WHETHER SUCH DAMAGES ARE PREDICATED OR BASED UPON BREACH OF WARRANTY, BREACH OF CONTRACT, NEGLIGENCE, STRICT TORT, OR ANY OTHER LEGAL THEORY. SUCH DAMAGES INCLUDE, BUT ARE NOT LIMITED TO, LOSS OF PROFITS, LOSS OF SAVINGS OR REVENUE, LOSS OF USE OF THE RADIO OR ANY ASSOCIATED EQUIPMENT, COST OF CAPITAL, COST OF ANY SUBSTITUTE EQUIPMENT, FACILITIES OR SERVICES, THE CLAIMS

---

1. The warranty against defects in ArWest adapter, antenna, battery, charger, or cable is 90 days.

## Warranty Terms

OF THIRD PARTIES, INCLUDING CUSTOMERS AND INJURY TO PROPERTY. THIS LIMITATION DOES NOT APPLY TO CLAIMS FOR PERSONAL INJURY. SOME STATES DO NOT ALLOW LIMITS ON WARRANTIES, OR ON REMEDIES FOR BREACH IN CERTAIN TRANSACTIONS. IN SUCH STATES, THE LIMITS IN THIS PARAGRAPH AND THE PRECEDING PARAGRAPH MAY NOT APPLY.

No employee of the Company, or any other party, is authorized to make any warranty in addition to those made in this document. This warranty allocates the risks of product failure between the Company and the buyer. This allocation is recognized by both parties and is reflected in the price of the goods. The buyer acknowledges that it has read this warranty, understands it, and is bound by its terms. This limited warranty is governed by the laws of the State of California, without reference to its conflict of law provisions or the U.N. Convention on Contracts for the International Sale of Goods.





1731 Technology Drive, San Jose, CA 95110 USA  
Tel+1 408 452 7719  
Fax: +1 408 452 7743  
**[www.arwestcom.com](http://www.arwestcom.com)**

Copyright © ArWest Communications, 2009  
All rights reserved. No unauthorized duplication.